



PVP1100, PVP2000, PVP3000

Highly-configurable, low power solar inverters for residential installations

The PVP1100, PVP2000, and PVP3000 inverters provide maximum energy harvest for smaller PV installations. With significant configuration flexibility, industry-leading reliability and easy jobsite installation, these inverters are ideally suited to the dynamic residential solar market. These units are ideal for integration into new and existing homes and, with proper planning, allow homeowners to expand their PV systems over time.

The inverters are available in extended and standard voltage range versions to best fit the needs of each installation. The Extended Voltage Range (115-500VDC) products offer the industry's lowest MPPT voltage and are the ideal choice for integration with next generation low voltage and building-integrated (BIPV) modules. The Standard Voltage Range (150-500VDC) products are optimized for traditional modules. Together, the entire product line offers the most design configurations across the widest range of PV modules.

Additional flexibility is provided by PV Powered's new ETL-listed and NEC code-compliant integration platform for both indoor and outdoor installations. Other system options include different mounting methods, AC and DC disconnects, inverter status display and wired or wireless data monitoring. This flexible approach enables visually pleasing, site-specific configurations that reduce permitting and inspection issues and reduce installation time.



Optional Performance Monitoring



Performance monitoring solutions are available on all PV Powered inverters and include low cost, secure web-based access to PV system status and performance history.

FEATURES

- **Flexible System Configurations**
 - Standard (150-500VDC) or Extended (115-500VDC) DC operating ranges
 - Lowest MPPT voltage (115VDC) improves compatibility with new low voltage and BIPV modules
 - ETL-listed integration platform saves installation time and errors
 - AC and DC disconnects
 - Indoor and outdoor configurations
 - Customizable data monitoring interface improves branding and customer experience.
- **Superior Reliability**
 - Significant software integration rather than complex hardware design
 - Field-proven reliability
- **Easy Installation**
 - No neutral required with three-wire AC installations
 - Meets revised UL1741 standard
 - Field-configurable grounding scheme with simple jumper selection
 - 10 knockouts for a variety of conduit routing options
 - Anti-corrosive NEMA 3R steel enclosure
- **Technical Support and Field Service.**
 - Industry leading service reimbursement policy
 - NABCEP-certified field service team*

150 SW Scalehouse Loop
Bend OR 97702

541-312-3832
WWW.PVPOWERED.COM

*In designated service zones only

DIMENSIONS

PVP1100, PVP2000, PVP3000

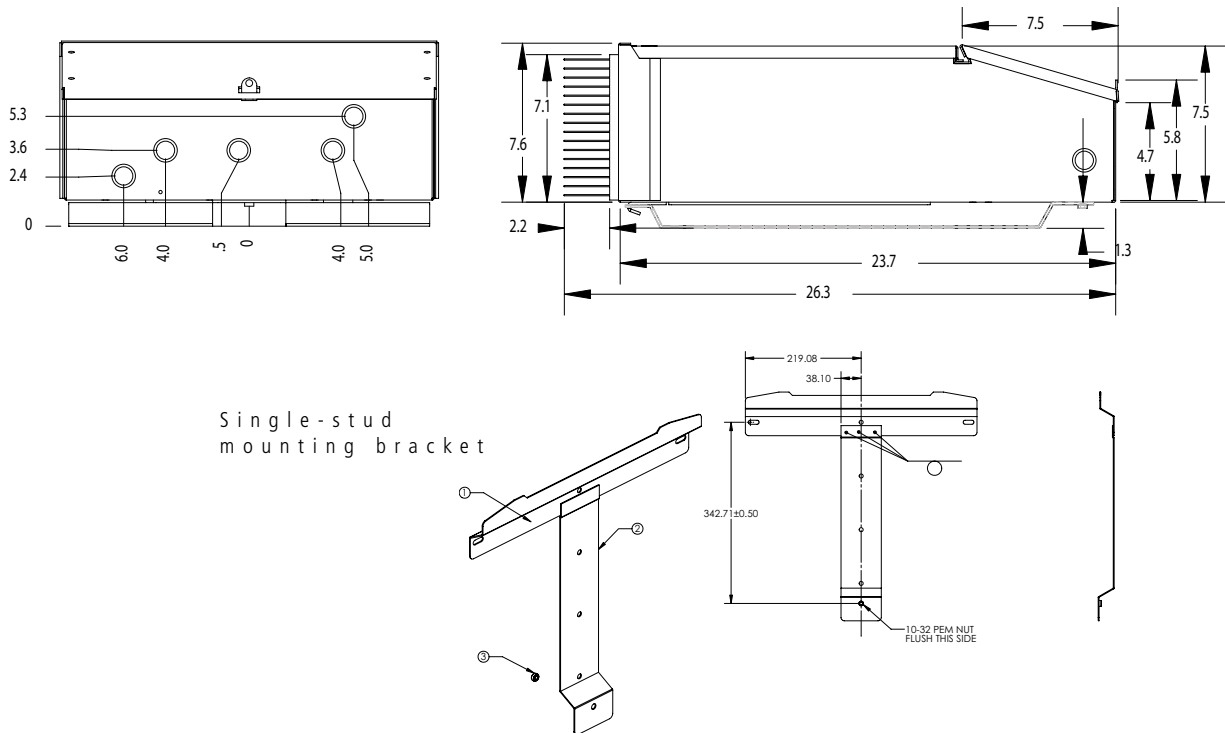

ELECTRICAL SPECIFICATIONS

MODEL	PVP1100		PVP2000		PVP3000
EVR = Extended Voltage Range SVR = Standard Voltage Range	EVR	SVR	EVR	SVR	SVR
Continuous Output Power (watts)	1100	1100	2000	2000	3000
Weighted CEC Efficiency (%)	92*	92.5*	92.5*	93*	93*
Maximum DC Input Voltage (VOC)	500	500	500	500	500
DC Voltage Operating Range (V)	115 - 500	150 - 500	115 - 500	150 - 500	170 - 500
DC Isc Maximum Current (A)	26	26	26	26	26
DC Imp Maximum Current (A)	13	13	20	20	20
AC Nominal Voltage (V)	120	120	240	240	240
AC Operating Range (V)	105.6 - 132.5	105.6 - 132.5	211 - 264	211 - 264	211 - 264
AC Frequency Range (Hz)	59.3 - 60.5	59.3 - 60.5	59.3 - 60.5	59.3 - 60.5	59.3 - 60.5
AC Maximum Continuous Current (A)	10	10	9	9	13

MECHANICAL SPECIFICATIONS

MODEL	PVP1100	PVP2000	PVP3000
NEMA 3R (Outdoor Rated) Sealed Powder Coated Electro-Magnetic Plated Steel Enclosure	X	X	X
Wall Mounted with Included Bracket	X	X	X
Weight (lbs)	55	65	80

AGENCY APPROVALS

MODEL	PVP1100	PVP2000	PVP3000
EEE 1547-compliant, UL 1741 Nov 2005 Revision and FCC Class A & B expected March 2008	X	X	X

* Pending CEC verification